

# Free Chlorine Sensor

For additional information, please visit our website  
 at [www.emersonprocess.com/raihome/liquid/](http://www.emersonprocess.com/raihome/liquid/).

## ⚠ CAUTION

**SENSOR/PROCESS APPLICATION COMPATIBILITY**  
 The wetted sensor materials may not be compatible with process composition and operating conditions. Application compatibility is entirely the responsibility of the user.

## ⚠ CAUTION

Do not exceed pressure and temperature specifications.  
 Pressure: 65 psig max (549 kPa abs max)  
 Temperature: 32 to 122°F (0 to 50°C)

## SPECIFICATIONS - SENSOR

**Pressure:** 0 to 65 psig (0 to 549 kPa abs)

**Temperature:** 32 to 122°F (0 to 50°C)

**Process Connection:** 1 inch MNPT

**Wetted Parts:** Noryl<sup>®1</sup>, Viton<sup>®2</sup>, platinum, polyethersulfone, polyester, wood, silicone

<sup>1</sup> Noryl is a registered trademark of General Electric.

<sup>2</sup> Viton is a registered trademark of DuPont Performance Elastomers

## SPECIFICATIONS - FLOW CELLS

Type	PN	Wetted Materials	Process Connection	Max. Temperature	Max. Pressure
1-1/2 in. tee	23567-00	CPVC, Buna N	1-1/2 in. socket	122°F (50°C)	65 psig (549 kPa abs)
2 in. tee	915240-03	PVC, Buna N	3/4 in. NFPT	120°F (49°C)	60 psig (515 kPa abs)
	915240-04		1 in. NFPT		
	915240-05		1-1/2 in. NFPT		
Low Flow*	24091-00	Polycarbonate/ polyester, 316SS, silicone	Compression fitting for 1/4 in. OD tubing	158°F (70°C)	90 psig (722 kPa abs)
	24091-01 (with bubble sweep- ing nozzle)	Polycarbonate/ polyester, 316SS, silicone	Compression fitting for 1/4 in. OD tubing	158°F (70°C)	90 psig (722 kPa abs)

\* Pressure and temperature specifications for the low flow cell exceed the temperature and pressure specifications for the sensor.

### INSTALLATION

Install the sensor in a flowing sample. Keep the sample flow as constant as possible at a value within the limits below.

Flow through	1 to 5 gpm (3.8 to 19 L/min)
Open channel	1 ft/sec (0.3 m/sec)
Low flow cell (PN 24091-00)	8 to 15 gph (30 to 57 L/hr)
Low flow cell (PN 24091-01)	2 to 3 gph (120 to 190 mL/min)

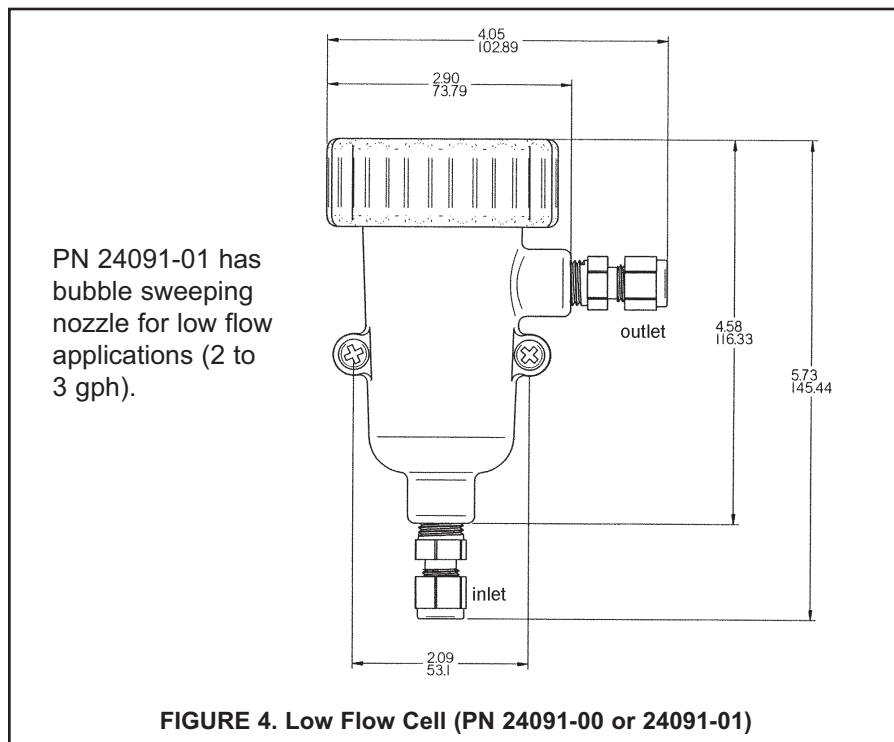
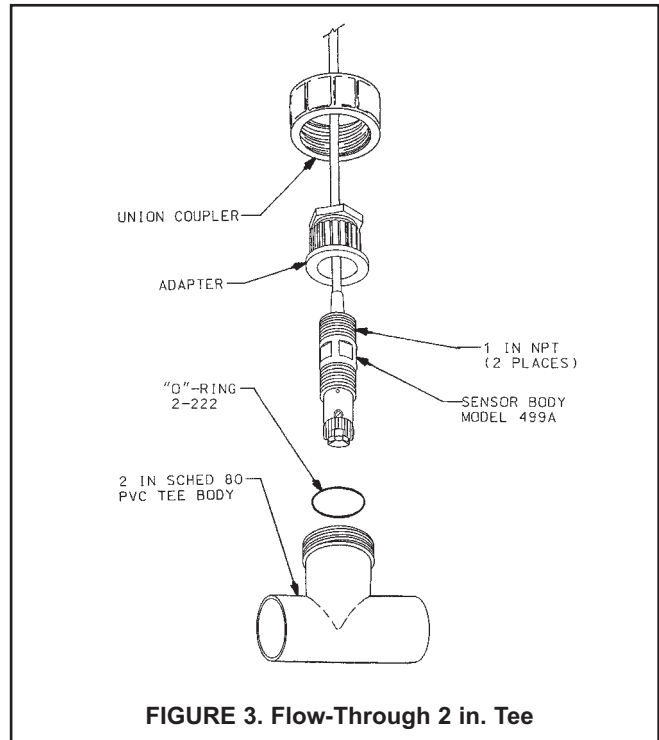
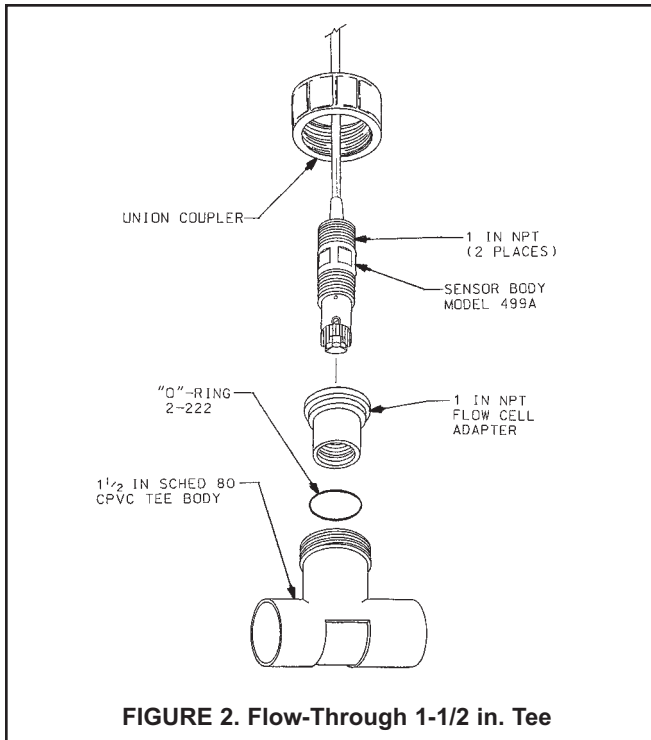
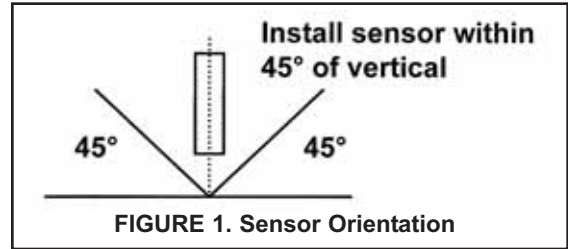

WIRING

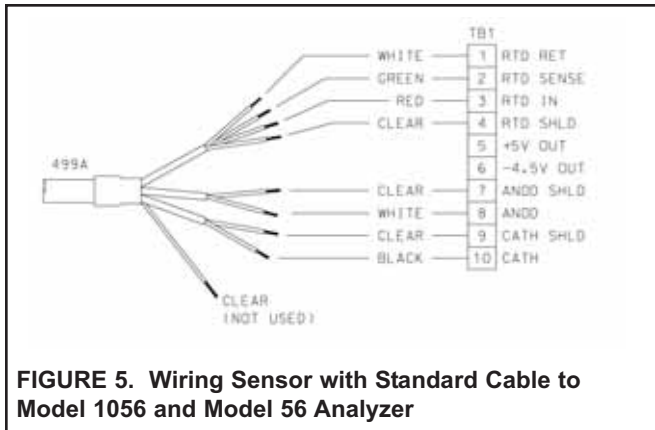

FIGURE 5. Wiring Sensor with Standard Cable to Model 1056 and Model 56 Analyzer

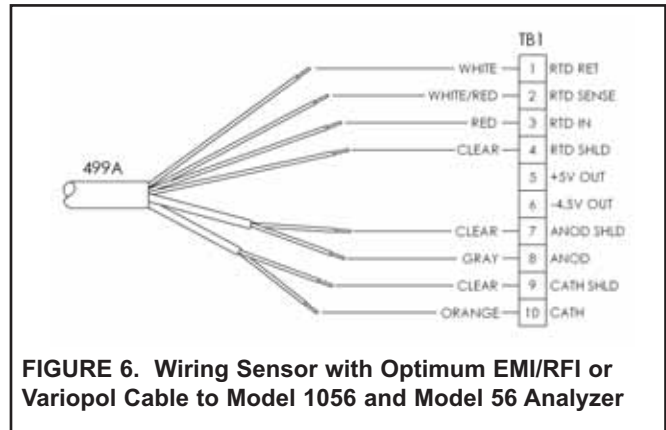

FIGURE 6. Wiring Sensor with Optimum EMI/RFI or Variopol Cable to Model 1056 and Model 56 Analyzer

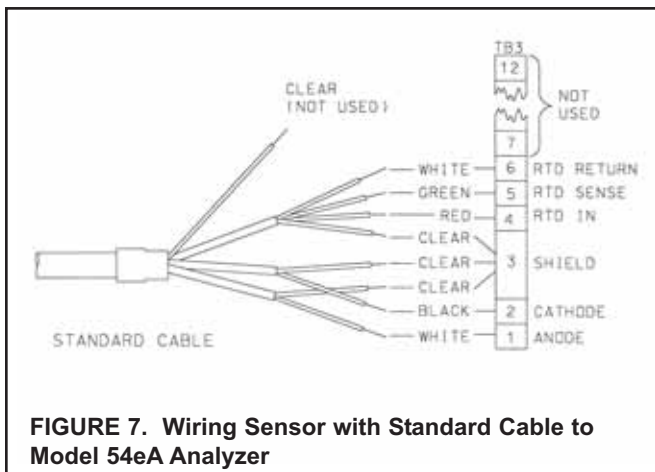

FIGURE 7. Wiring Sensor with Standard Cable to Model 54eA Analyzer

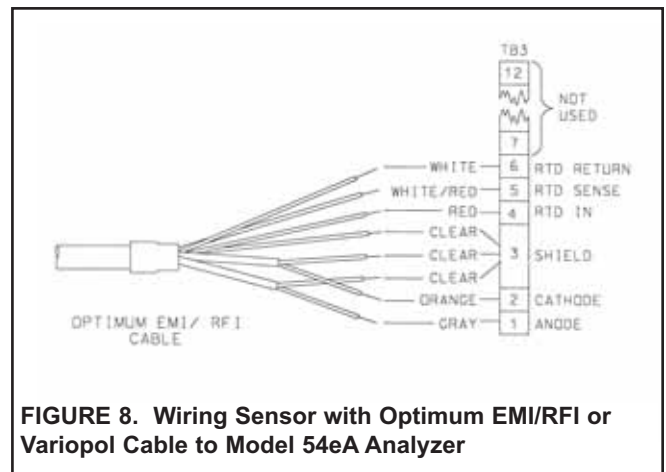
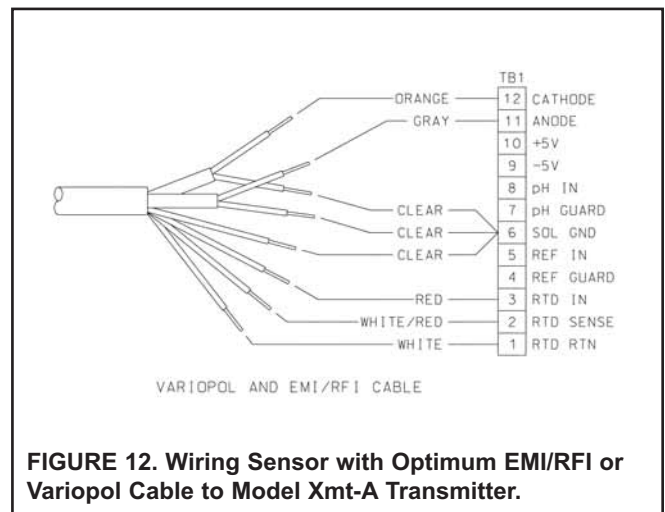
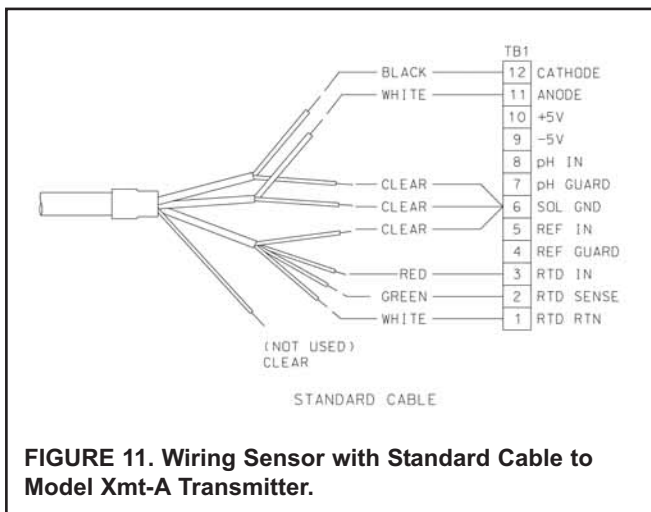
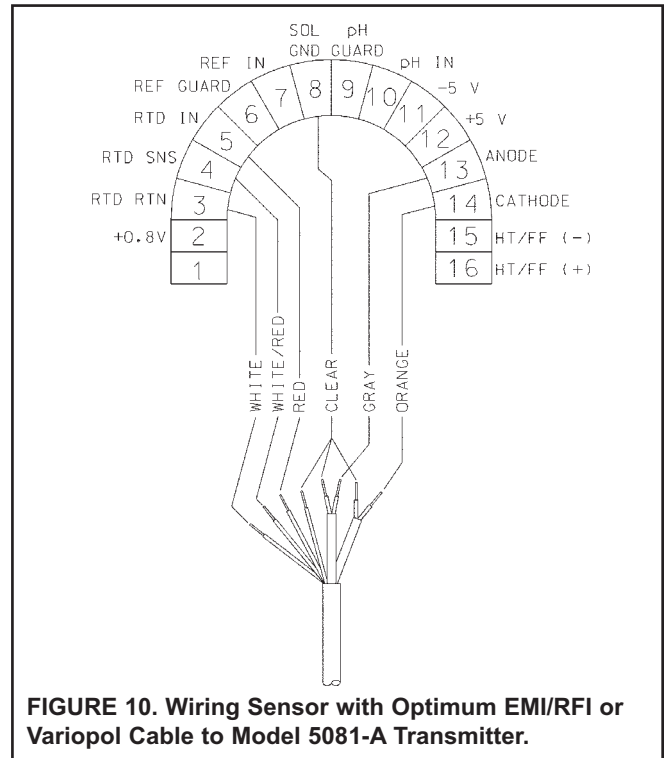
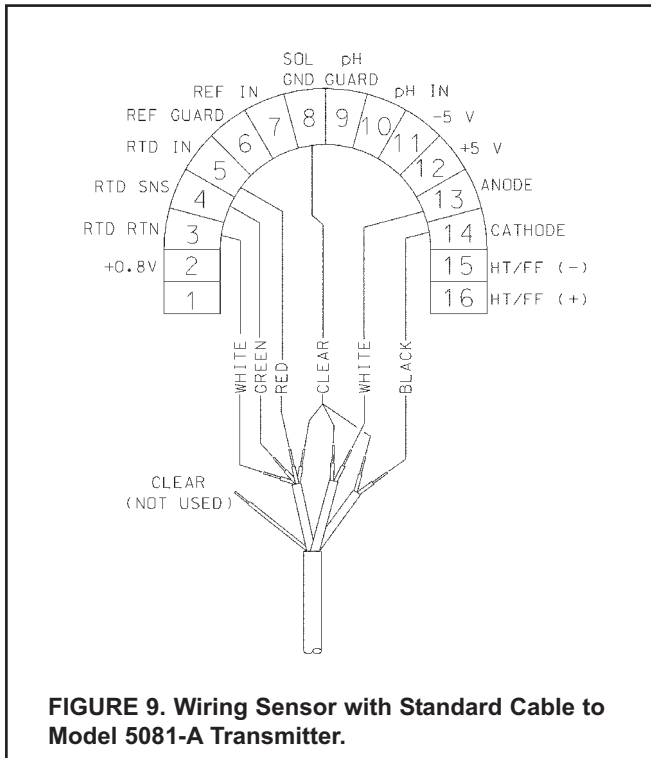

FIGURE 8. Wiring Sensor with Optimum EMI/RFI or Variopol Cable to Model 54eA Analyzer



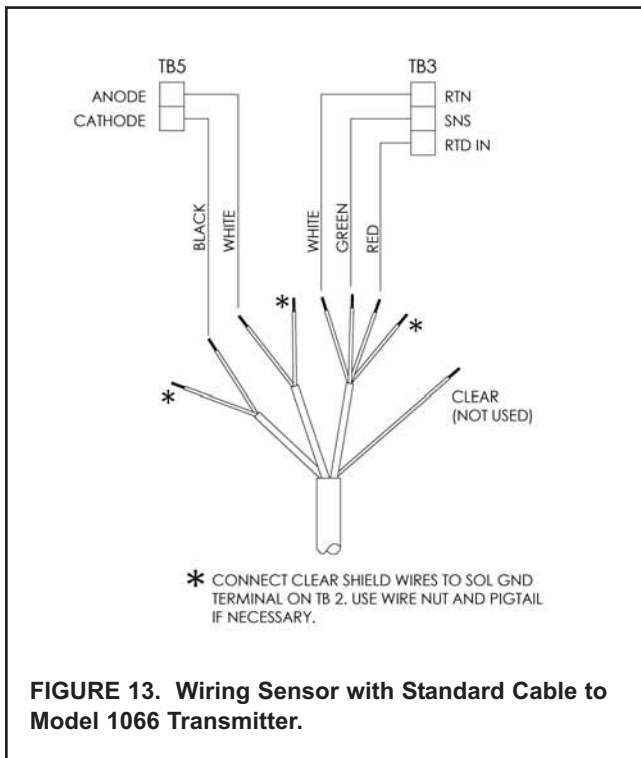

FIGURE 13. Wiring Sensor with Standard Cable to Model 1066 Transmitter.

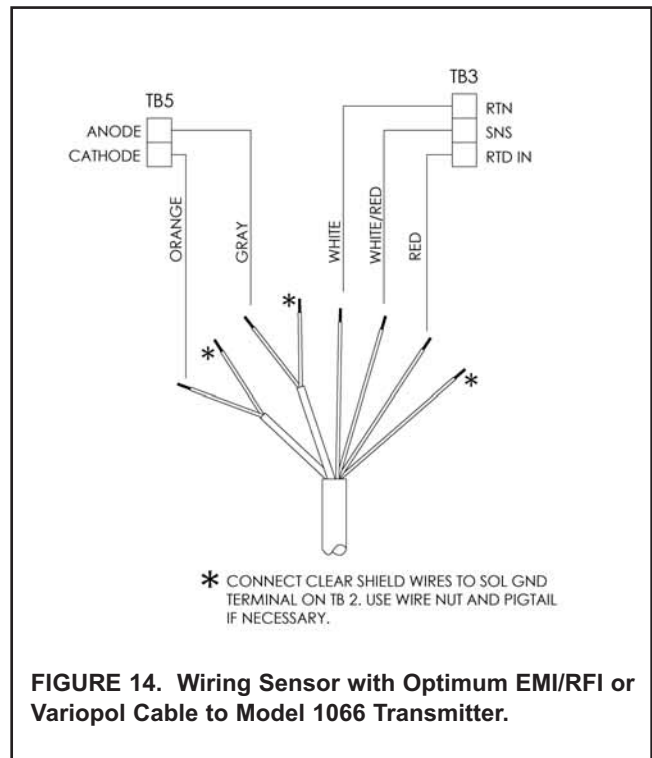

FIGURE 14. Wiring Sensor with Optimum EMI/RFI or Variopole Cable to Model 1066 Transmitter.

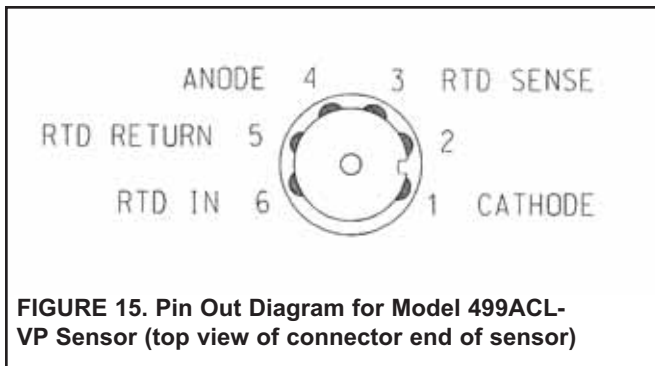

FIGURE 15. Pin Out Diagram for Model 499ACL-VP Sensor (top view of connector end of sensor)

When making connections through a junction box (PN 23550-00), wire point-to-point.

**NOTE:**

**Use a wire nut and pigtail (included) when connecting several wires to the same terminal.**

**CALIBRATION**

**Zero point:** Even in the absence of free chlorine, the 499ACL-01 sensor generates a small signal called the zero current. Failing to correct for the zero current can introduce a bias, particularly if the chlorine concentration is small (<0.4 ppm). Zero the sensor when it is first placed in service and every time the fill solution is changed. To zero the sensor, place it in a cup of deionized or bottled water to which a few pinches of table salt have been added to increase the conductivity. Once the sensor current has reached a stable low value, which takes at least two hours, follow the analyzer prompts for zeroing the sensor. The zero current should be between -10 and +10 nA. For more information refer to the analyzer manual.

**Full Scale:** Because stable dilute chlorine standards are not available, the sensor must be calibrated against the results of a laboratory test run on a grab sample of the process liquid. Place the sensor in the flow cell and adjust the sample flow to within the range given in the table on page 2. Also, adjust the concentration so that it is near the upper end of the operating range. Once readings are stable, follow the analyzer prompts to complete the calibration. Be sure taking the sample does not alter flow to the sensor and test the sample immediately after taking it. After calibration, go to the diagnostics menu and check the sensitivity. It should be between 200 and 450 nA/ppm. For more information, refer to the analyzer manual.

## MAINTENANCE

Periodic maintenance and cleaning are required for best performance of the sensor. Generally, the membrane and fill solution should be replaced every one to three months. If the sensor is being used in water having conductivity less than about 100  $\mu\text{S}/\text{cm}$ , it might be necessary to replace the fill solution (but not the membrane) more often. Sensors installed in harsh or dirty environments require more frequent maintenance. The optimum maintenance frequency is best determined by experience.



### CAUTION

#### PRESSURIZED SPRAY INJURY

Before removing the sensor, be absolutely certain that the process pressure is reduced to 0 psig and the process temperature is lowered to a safe level!

### CLEANING THE MEMBRANE.

Keep the membrane clean and free from dirt and algae. Clean the membrane with water sprayed from a wash bottle. **Do not use tissues to clean the membrane.**

### REPLACING THE ELECTROLYTE SOLUTION AND MEMBRANE.



### CAUTION

Fill solution may cause irritation. May be harmful if swallowed. Read and follow manual.

- Unscrew the membrane retainer and remove the membrane assembly and O-ring. See Figure 16.
- Hold the sensor over a container with the cathode pointing down.
- Remove the fill plug and allow the electrolyte solution to drain out.
- Inspect the cathode. If it is tarnished, clean it using a cotton-tipped swab dipped in baking soda or alumina. Use type A dry powder alumina intended for metallographic polishing of medium and soft metals. Rinse thoroughly with water.
- Wrap the plug with one or two turns of pipe tape. Remove old tape first.
- Prepare a new membrane. Hold the membrane assembly with the cup formed by the membrane and membrane holder pointing up. Fill the cup with electrolyte solution and allow the wooden ring to soak up the solution (usually takes several minutes).
- Hold the sensor at about a 45-degree angle with the cathode end pointing up. Add electrolyte solution through the fill hole until the liquid overflows. Tap the sensor near the threads to release trapped air bubbles. Add more electrolyte solution if necessary.
- Place the fill plug in the electrolyte port and begin screwing it in. After several threads have engaged, rotate the sensor so that the cathode is pointing up and continue tightening the fill plug. Do not overtighten.
- Place a new O-ring in the groove around the cathode post. Cover the holes at the base of the cathode stem with several drops of electrolyte solution.
- Insert a small **blunt** probe, like a toothpick with the end cut off, through the pressure equalizing port. See Figure 16.

#### NOTE

**Do not use a sharp probe. It will puncture the bladder and destroy the sensor.**

Gently press the probe against the bladder several times to force liquid through the holes at the base of the cathode stem. Keep pressing the bladder until no air bubbles can be seen leaving the holes. Be sure the holes remain covered with electrolyte solution.

- Place a drop of electrolyte solution on the cathode, then place the membrane assembly over the cathode. Screw the membrane retainer in place.
- The sensor may require several hours operating at the polarizing voltage to equilibrate after the electrolyte solution has been replenished.

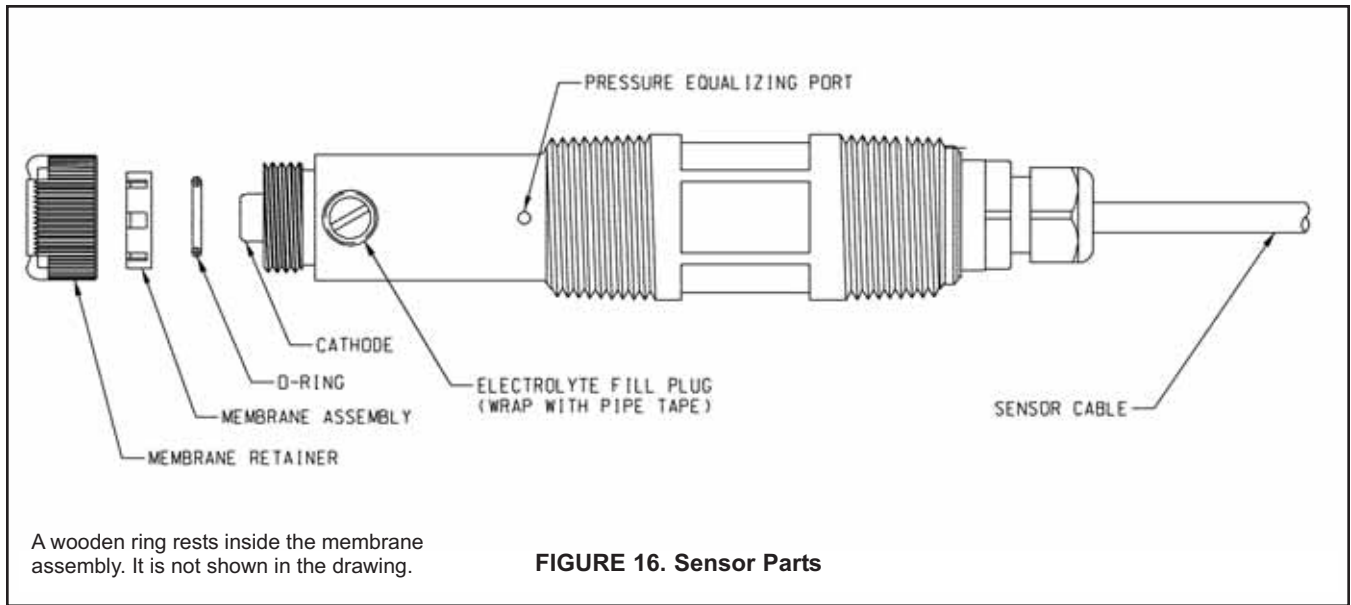

A wooden ring rests inside the membrane assembly. It is not shown in the drawing.

**FIGURE 16. Sensor Parts**

**SPARE PARTS**

33523-00	Electrolyte Fill Plug
9550094	O-Ring, Viton 2-014
33521-00	Membrane Retainer
23501-08	Free Chlorine Membrane Assembly: includes one membrane assembly and one O-ring
23502-08	Free Chlorine Membrane Kit: includes 3 membrane assemblies and 3 O-rings
9210356	#4 Free Chlorine Sensor Fill Solution, 4 oz (120 mL)



*The right people,  
the right answers,  
right now.*

**ROSEMOUNT ANALYTICAL  
CUSTOMER SUPPORT CENTER  
1-800-854-8257**



**Emerson Process Management**

2400 Barranca Parkway  
Irvine, CA 92606 USA  
Tel: (949) 757-8500  
Fax: (949) 474-7250  
<http://www.raihome.com>



ON-LINE ORDERING NOW AVAILABLE ON OUR WEB SITE  
<http://www.raihome.com>

*Specifications subject to change without notice.*

Credit Cards for U.S. Purchases Only.

